



# VG101

Cellular-band Variable Gain Amplifier

The Communications Edge™

Product Information

## Product Features

- 750 – 1000 MHz bandwidth
- 28 dB Attenuation Range
- +40 dBm Output IP3
- +22 dBm P1dB
- Constant IP3 & P1dB over attenuation range
- Single voltage supply
- Pb-free 6mm 28-pin QFN package
- MTTF > 1000 years

## Applications

- Xmit & Rcv AGC circuitry for mobile infrastructure

## Product Description

The VG101 is a cellular-band high dynamic range variable gain amplifier (VGA) packaged in a low profile Pb-free / RoHS-compliant surface-mount leadless package that measures 6 x 6 mm square.

The +22 dBm output compression point and +40 dBm output intercept point of the amplifier are maintained over the entire attenuation range, making the VG101 ideal for use in transmitter and receiver AGC circuits and as a variable gain stage following an LNA in high dynamic range receiver front ends.

Superior thermal design allows the product to have a minimum MTTF rating of 1000 years at a mounting temperature of +85 °C. All devices are 100% RF & DC tested and packaged on tape and reel for automated surface-mount assembly.

## Functional Diagram

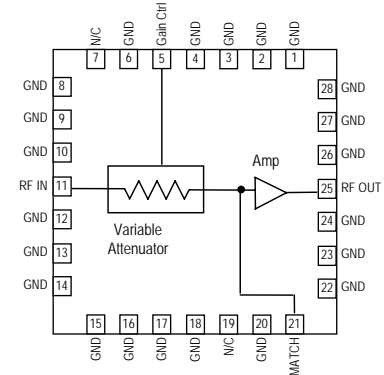

Function	Pin No
Gain Control	5
No Connect	7, 19
RF Input	11
Interstage Match	21
RF Output / DC bias	25
Ground	All other pins Backside copper

## Specifications <sup>(1)</sup>

Parameter	Units	Min	Typ	Max	Conditions
Operational Bandwidth	MHz	750		1000	
Test Frequency	MHz		900		See note 1
Gain at min. attenuation	dB	15	16		
Input Return Loss	dB		12		
Output Return Loss	dB		10		
Output P1dB	dBm		+22		
Output IP3	dBm	+37	+40		See note 2
Noise Figure at min. attenuation	dB		3		$V_{CTRL} = 0 V$
Gain Variation Range	dB	25.5	28.7	33.5	See note 3
Gain Variation Control Voltage, $V_{CTRL}$	V	0		4.5	See note 1
Group Delay	ns		1		Frequency = 900 MHz
Supply Voltage	V		+5		
Operating Amplifier Current Range	mA	120	150	180	Pin 25
Gain Control Pin Current	mA			20	$V_{CTRL} = 4.5 V$ . See note 1.

1. Test conditions unless otherwise noted: 25°C, Vdd = +5 V in a tuned application circuit. Vctrl is the control voltage through a BJT transistor and a 100 Ω dropping resistor as shown in the same application circuit.
2. 3OIP measured with two tones at an output power of +5 dBm/tone separated by 10 MHz. The suppression on the largest IM3 product is used to calculate the 3OIP using a 2:1 rule.
3. The gain variation range is measured as the difference in gain with Vctrl = 0V and Vctrl = 4.5V at 0.9 GHz.

## Absolute Maximum Rating

Parameter	Rating
Operating Case Temperature	-40 to +85 °C
Storage Temperature	-55 to +125 °C
Amplifier Supply Voltage (pin 25)	+6 V
Pin 5 (Gain Control) Current	30 mA
RF Input Power (continuous)	+12 dBm
Junction Temperature	+220 °C

Operation of this device above any of these parameters may cause permanent damage.

## Ordering Information

Part No.	Description
VG101*	Cellular-band Variable Gain Amplifier (tin-lead 6mm QFN package)
VG101-F	Cellular-band Variable Gain Amplifier (lead-free/RoHS-compliant QFN package)
VG101-PCB	Fully Assembled Application Board

\* This package is being phased out in favor of the lead-free/RoHS-compliant package type which is backwards compatible for existing designs. Refer to WJPCN06MAY05TC1 on the WJ website.

Specifications and information are subject to change without notice



# VG101

Cellular-band Variable Gain Amplifier

The Communications Edge™

Product Information

## Application Circuit: 750 – 1000 MHz (VG101-PCB)

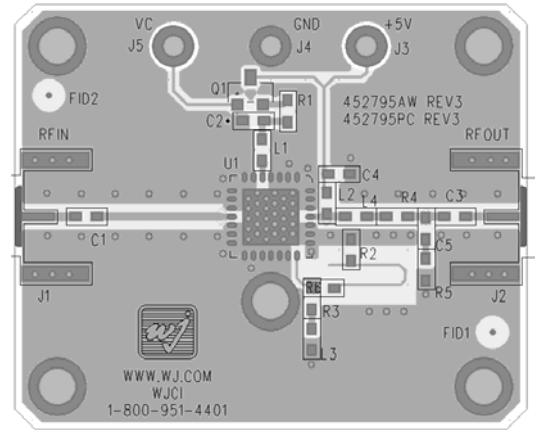
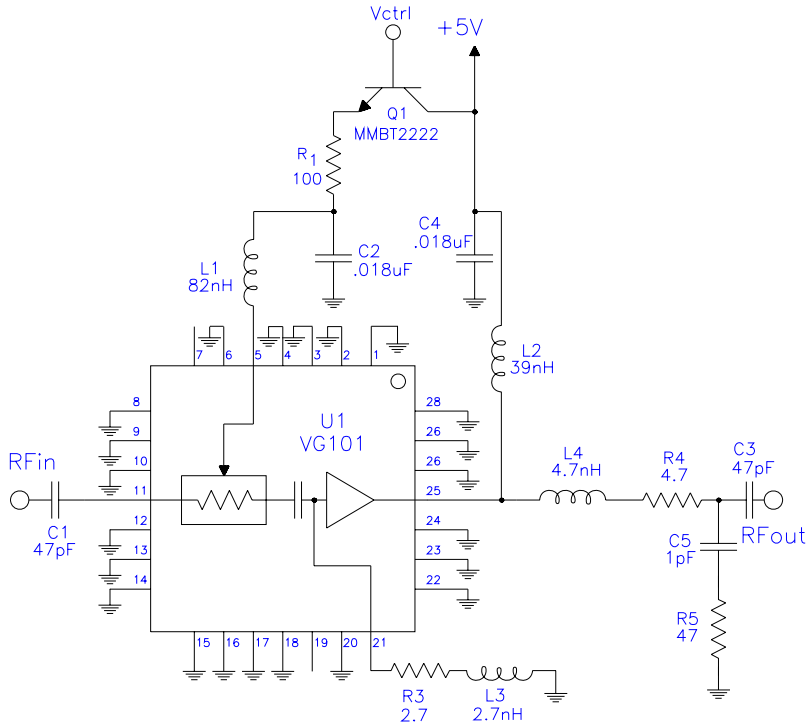

Circuit Board Material: .014" FR-4, 4 layers, .062" total thickness

- The amplifier is biased through Pin 25 and should be connected directly into a voltage regulator.
- Distances are shown from the edge-to-edge for the land pattern.

### Bill of Materials

Ref. Des.	Description	Size
C1, C3	47 pF Chip Capacitor	0603
C2, C4	0.01 μF Chip Capacitor	0603
C5	1 pF Chip Capacitor	0603
L1	82 nH Chip Inductor	0603
L2	39 nH Chip Inductor	0603
L3	2.7 nH Chip Inductor	0603
L4	8.2 nH Chip Inductor	0603
R1	100 Ω Chip Resistor	0603
R3	2.7 Ω Chip Resistor	0603
R4	4.7 Ω Chip Resistor	0603
R5	47 Ω Chip Resistor	0603
Q1	MMBT2222 Motorola Transistor	SOT-23
U1	VG101 Variable Gain Amplifier	QFN 6x6

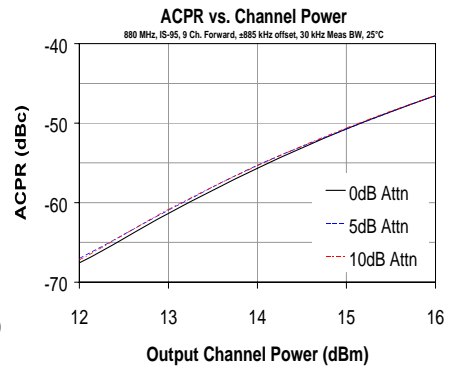
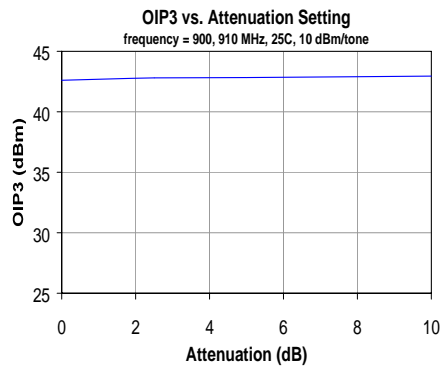
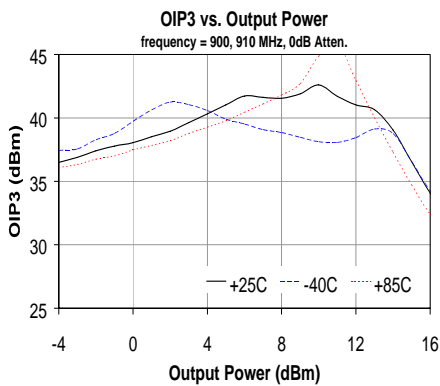

Specifications and information are subject to change without notice



## VG101-PCB Application Circuit Performance (cont'd)

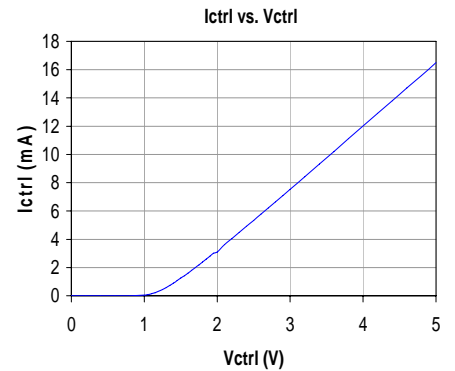
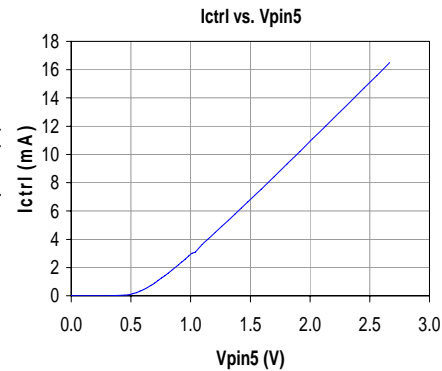
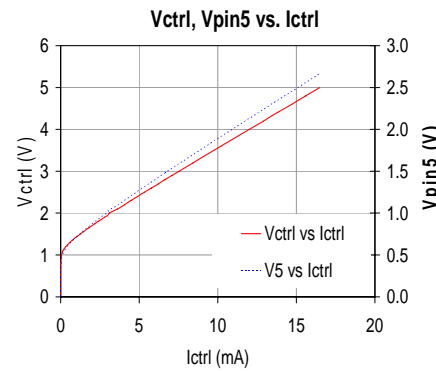
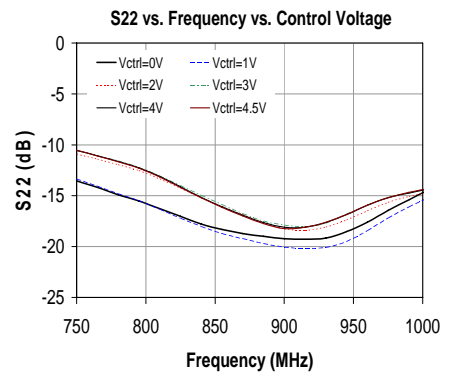
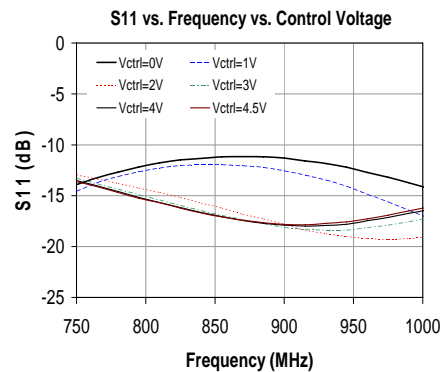
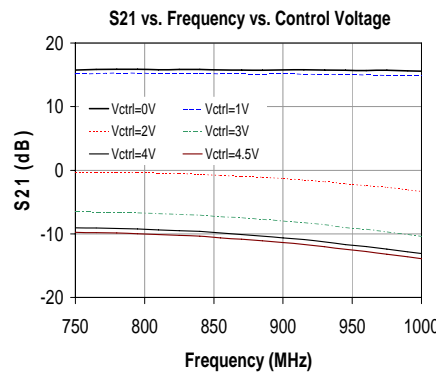
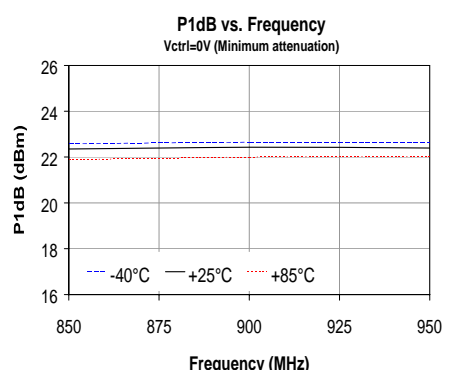
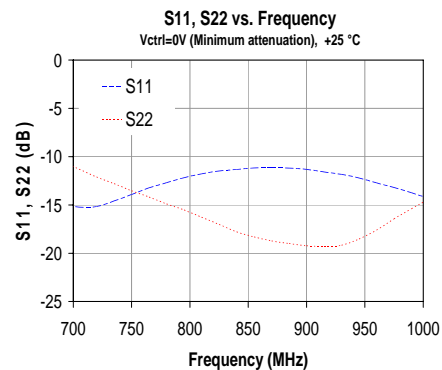
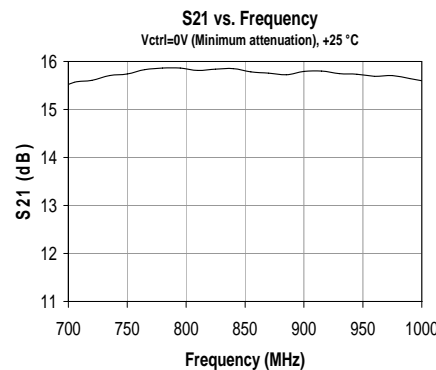
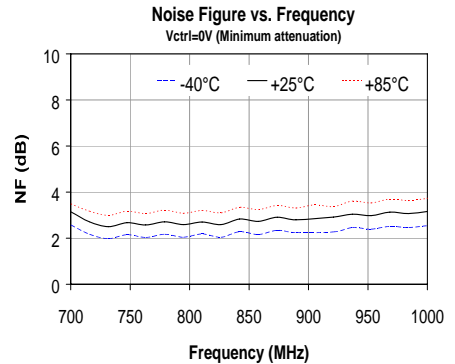
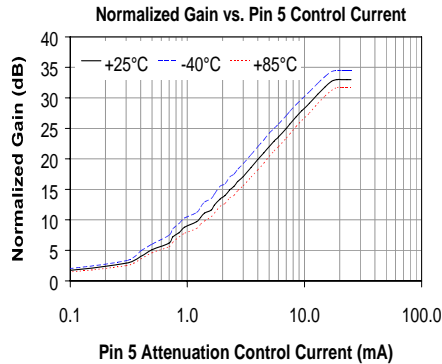
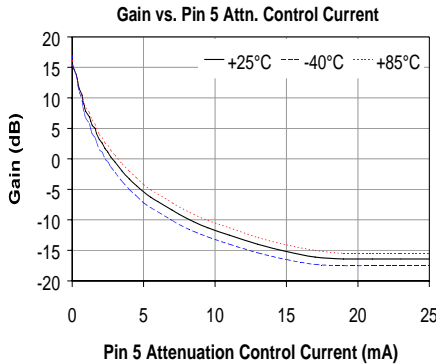



### VG101 Mechanical Information

This package may contain lead-bearing materials. The plating material on the pins is SnPb.

#### Outline Drawing

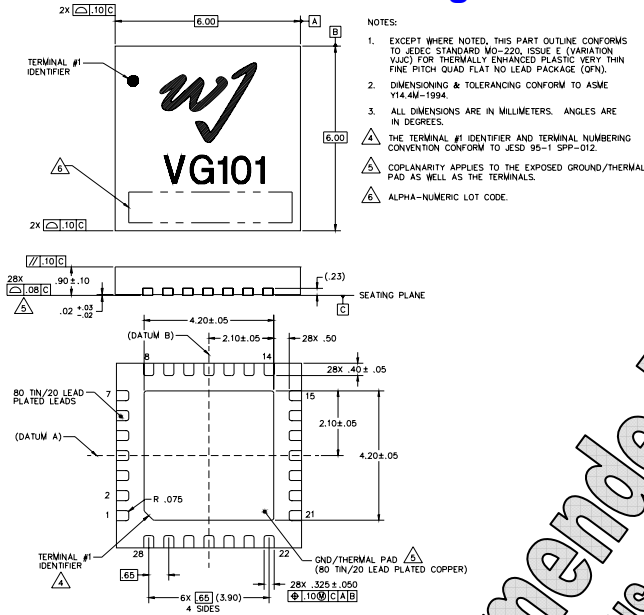

#### Product Marking

The component will be user marked on a "VG101" designator with an alpha-numeric lot code on the top surface of the package.

Tap and reel specifications for this part will be located on the website in the "Application Notes" section.

#### ESD/MSD Information

Caution: ESD sensitive device.

- Rating: Class 1B
- Class: Passes  $\geq 500V$  to  $<1000V$
- Test: Human Body Model (HBM)
- Standard: JEDEC Standard JESD22-A114
- Rating: Class IV
- Class: Passes  $\geq 1000V$  to  $<2000V$
- Test: Charged Device Model (CDM)
- Standard: JEDEC Standard JESD22-C101
- MSL: Level 1 at  $+250^\circ C$  convection reflow
- Standard: JEDEC Standard J-STD-020

#### Mounting Configuration / Land Pattern

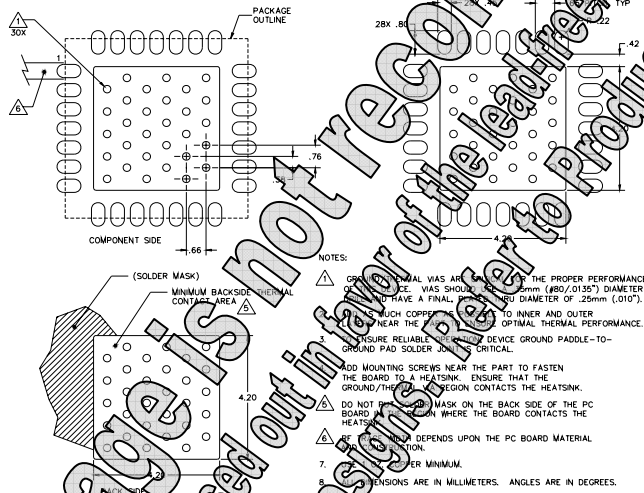

#### Functional Pin Layout

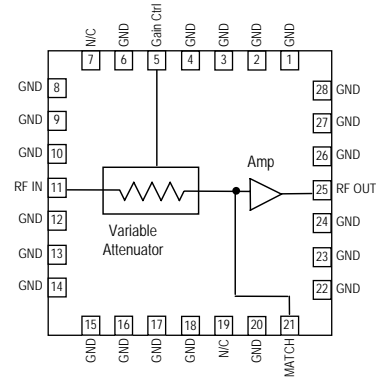

Pin	FUNCTION	Pin	FUNCTION
1	GND	15	GND
2	GND	16	GND
3	GND	17	GND
4	GND	18	GND
5	Gain control pin	19	N/C
6	GND	20	GND
7	N/C	21	Interstage Match
8	GND	22	GND
9	GND	23	GND
10	GND	24	GND
11	RF Input	25	RF Output / Bias
12	GND	26	GND
13	GND	27	GND
14	GND	28	GND

#### Thermal Specifications

**Parameter**      **Typical Value**

Operating Case Temperature,  $T_{OC}$        $0$  to  $+85^\circ C$

Thermal Resistance,  $R_{th(1)}$        $9^\circ C/W$

Junction Temperature,  $T_{JC(2)}$        $129^\circ C$

<sup>(1)</sup> Thermal resistance is referenced from the hottest part of the junction to the ground tab (pin 4). This corresponds to the typical biasing condition of  $+5V$ ,  $5mA$  at  $85^\circ C$  case temperature. A minimum MTTF of one million hours is achieved for operation temperatures below  $160^\circ C$ .

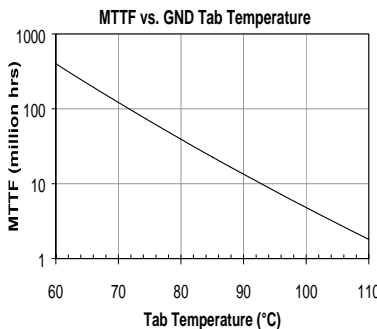



## VG101-F Mechanical Information

This package is lead-free/RoHS-compliant. It is compatible with both lead-free (maximum 260°C reflow temperature) and leaded (maximum 245°C reflow temperature) soldering processes. The plating material on the pins is annealed matte tin over copper.

### Outline Drawing

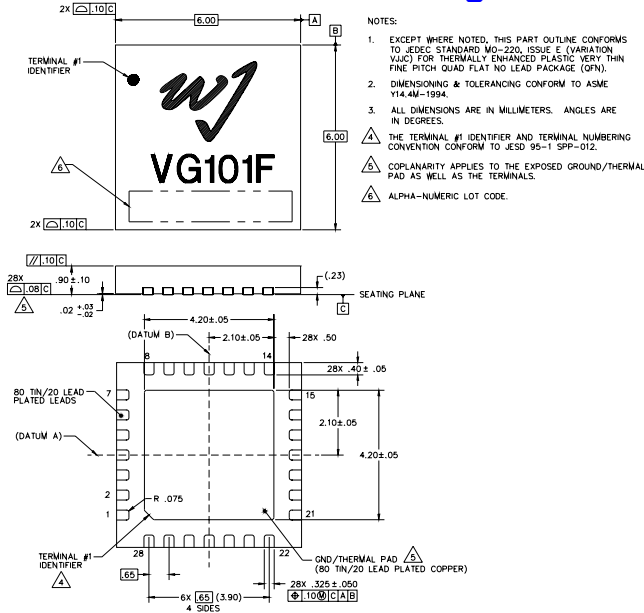

### Product Marking

The component will be lasermarked with a “VG101F” designator with an alphanumeric lot code on the top surface of the package.

Tape and reel specifications for this part will be located on the website in the “Application Notes” section.

### ESD / MSL Information



Caution! ESD sensitive device.

ESD Rating: Class 1B  
 Value: Passes  $\geq 500V$  to  $<1000V$   
 Test: Human Body Model (HBM)  
 Standard: JEDEC Standard JESD22-A114

ESD Rating: Class IV  
 Value: Passes  $\geq 1000V$  to  $<2000V$   
 Test: Charged Device Model (CDM)  
 Standard: JEDEC Standard JESD22-C101

MSL Rating: Level 2 at  $+260^{\circ}C$  convection reflow  
 Standard: JEDEC Standard J-STD-020

### Mounting Configuration / Land Pattern

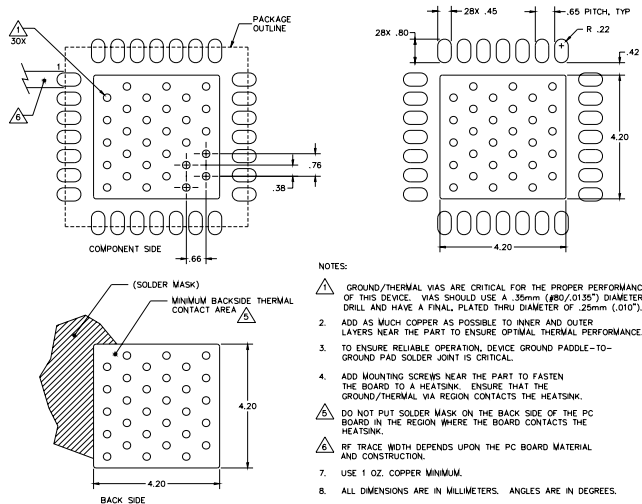

### Functional Pin Layout

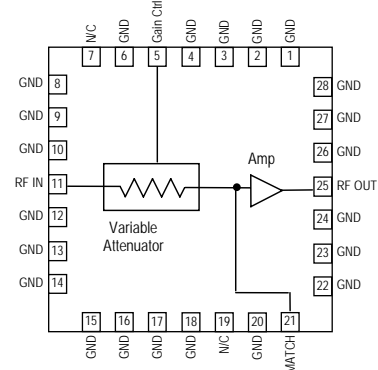

Pin	FUNCTION	Pin	FUNCTION
1	GND	15	GND
2	GND	16	GND
3	GND	17	GND
4	GND	18	GND
5	Gain control pin	19	N/C
6	GND	20	GND
7	N/C	21	Interstage Match
8	GND	22	GND
9	GND	23	GND
10	GND	24	GND
11	RF Input	25	RF Output / Bias
12	GND	26	GND
13	GND	27	GND
14	GND	28	GND

### Thermal Specifications

Parameter	Rating
Operating Case Temperature	-40 to +85° C
Thermal Resistance, Rth <sup>(1)</sup>	59° C / W
Junction Temperature, Tjc <sup>(2)</sup>	129° C

- The thermal resistance is referenced from the hottest part of the junction to the ground tab (pin 4).
- This corresponds to the typical biasing condition of +5V, 150 mA at an 85° C case temperature. A minimum MTTF of 1 million hours is achieved for junction temperatures below 160° C.

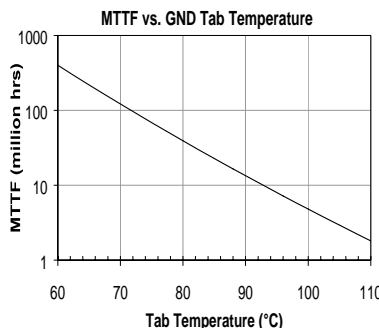

Specifications and information are subject to change without notice